

PM/CHT

PM/CHT - DFP

- Doppia flangia piana
- Double flat flange

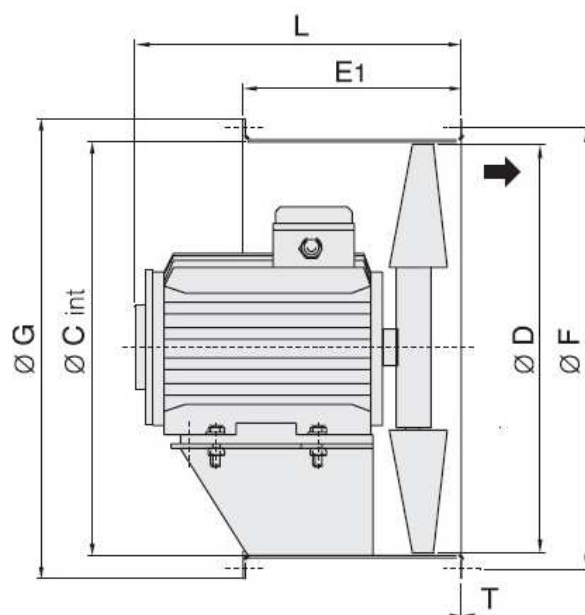

Modello Type	Motore Motor	Dimensioni Dimensions								Fori Holes		PMHT PM/CHT	
		H	C	D	E	E1	F	G	L	T	n°	Ø	kg
400	100	410	395	300	215	440	473	390	1,5	6	11	53,5	50
450	100	460	445	400	230	495	523	395	1,5	6	11	57,5	53
500	132	510	495	450	270	545	573	470	1,5	8	11	106	100,5
560	132	570	555	500	300	605	633	470	1,5	8	11	114	107,5
630	100	640	620	500	300	675	704	465	2	8	11	84	77
710	112	710	690	500	300	745	774	465	2	12	14	98	88,5
	132	710	690	500	300	745	774	495	2	12	14	123	113,5
800	100	810	790	560	350	855	884	500	2	12	14	96,5	86
	112	810	790	560	350	855	884	500	2	12	14	106,5	96
	132	810	790	560	350	855	884	545	2	12	14	144,5	134
900	112	910	890	650	500	955	1004	610	3	16	14	160	131,5
	132	910	890	650	500	955	1004	610	3	16	14	196	167,5
	160	910	890	650	500	955	1004	700	3	16	14	273	244,5
1000	112	1010	990	650	500	1070	1104	610	3	16	14	164	135,5
	132	1010	990	650	500	1070	1104	610	3	16	14	203	174,5
	160	1010	990	650	500	1070	1104	700	3	16	14	277	248,5
1120	132	1130	1110	900	550	1185	1240	670	3	20	16	237	200
	160	1130	1110	900	550	1185	1240	710	3	20	16	307	270
1250	132	1260	1240	1000	550	1320	1370	820	3	20	16	279	235
	160	1260	1240	1000	550	1320	1370	820	3	20	16	349	305
	180	1260	1240	1000	550	1320	1370	820	3	20	16	398	354
1400	180	1410	1390	1120	550	1465	1520	820	3	20	16	443	381
	200	1410	1390	1120	550	1465	1520	850	3	20	16	519	457